

Intensive Dampener *GYT*



Excellent Milling Properties...

WORKING PRINCIPLES

Allows the product to be mixed with the product before the grinding process to bring it to the desired moisture content. During the humidification process, the machine's design and uniform water distribution allow water to penetrate into the grain faster and more efficiently using less water. Thanks to the design of the machine, the breakage and wear of the product granules is reduced to a minimum level. With this machine 5% - 7% water can be given to the product.



Product Data Sheet

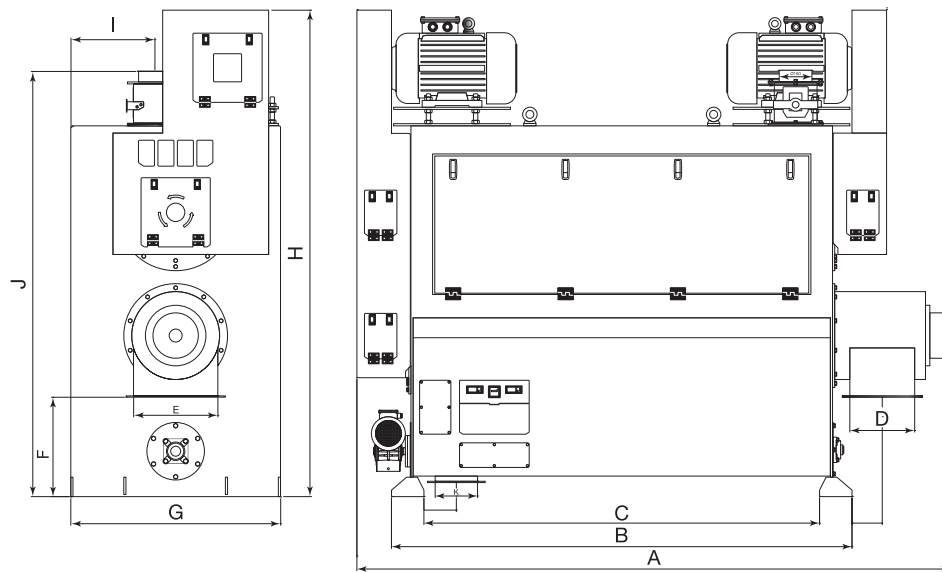

Type	Technical Features			Dimensions (mm)										Weight (kg)	
	Capacity (t/h)	Volume (m ³)	Power (kW)	A	B	C	D	E	F	G	H	I	J		K
GYT 10	10	5.99	2 x 11 1 x 1.1												1870
GYT 15	15	5.99	2 x 15 1 x 1.1	2748	2130	1830	300	390	460	970	2250	3885	1968	196 x 196	2215
GYT 20	20	5.99	2 x 22 1 x 1.1												2195