

Inclined Intensive Dampener GAC

Gmach

Excellent Milling Properties...

WORKING PRINCIPLES

The inclined intensive dampener's rotor system provides intensive but gentle dampening of grain with a moisture addition level. The two-component injection system and the high material whirling via special rotor result in optimal intermixing with the atomized liquid, thus ensuring efficient moisture addition in flours and brans.



Product Data Sheet

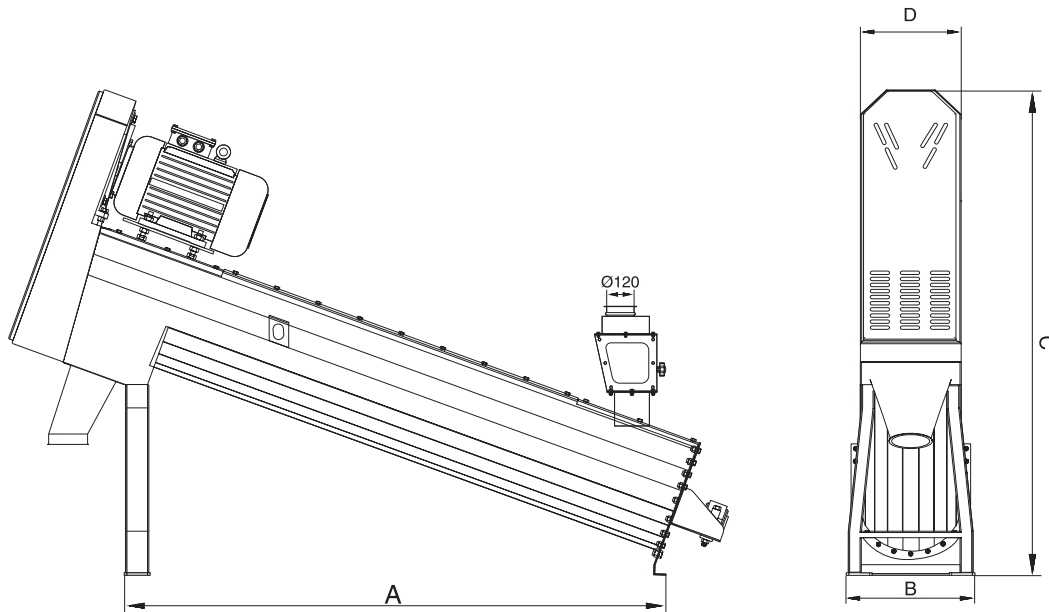

Type	Technical Features			Dimensions (mm)				Weight (kg)
	Capacity (t/h)	Volume (m ³)	Power(kW)	A	B	C	D	
GAC 250	6-8	11	7.5	1930	450	1760	375	375
GAC 350	10-15	13	11	2800	612	2005	500	550
GAC 500	15-20	15	15	2140	712	1950	540	750
GAC 600	30-45	20	22	2080	710	2135	635	550