

# FOURCLEAN

Combi Cleaner / GKC



*Excellent Milling Properties...*

## WORKING PRINCIPLES

FourClean separates impurities from grain such as dust, sand, stones, broken and weak grains. Thanks to compact design of machine, it does the operation that can be done by four machines, in minimum space.

At first stage, separates the products by their size as bigger and smaller things by vibration. Thanks to this vibration, grain flows and clean up by sifting. Sieves size and types are changeable according to product type.

At second stage, separating heavy and big grains.

At third stage, separates high density things from grain such as glass, stone etc. Thanks to air aspiration of inside of machine, product flows on sieve and high density things moves opposite way of product by vibration.

At fourth stage, separate unwanted low density materials in grain by negative pressure.

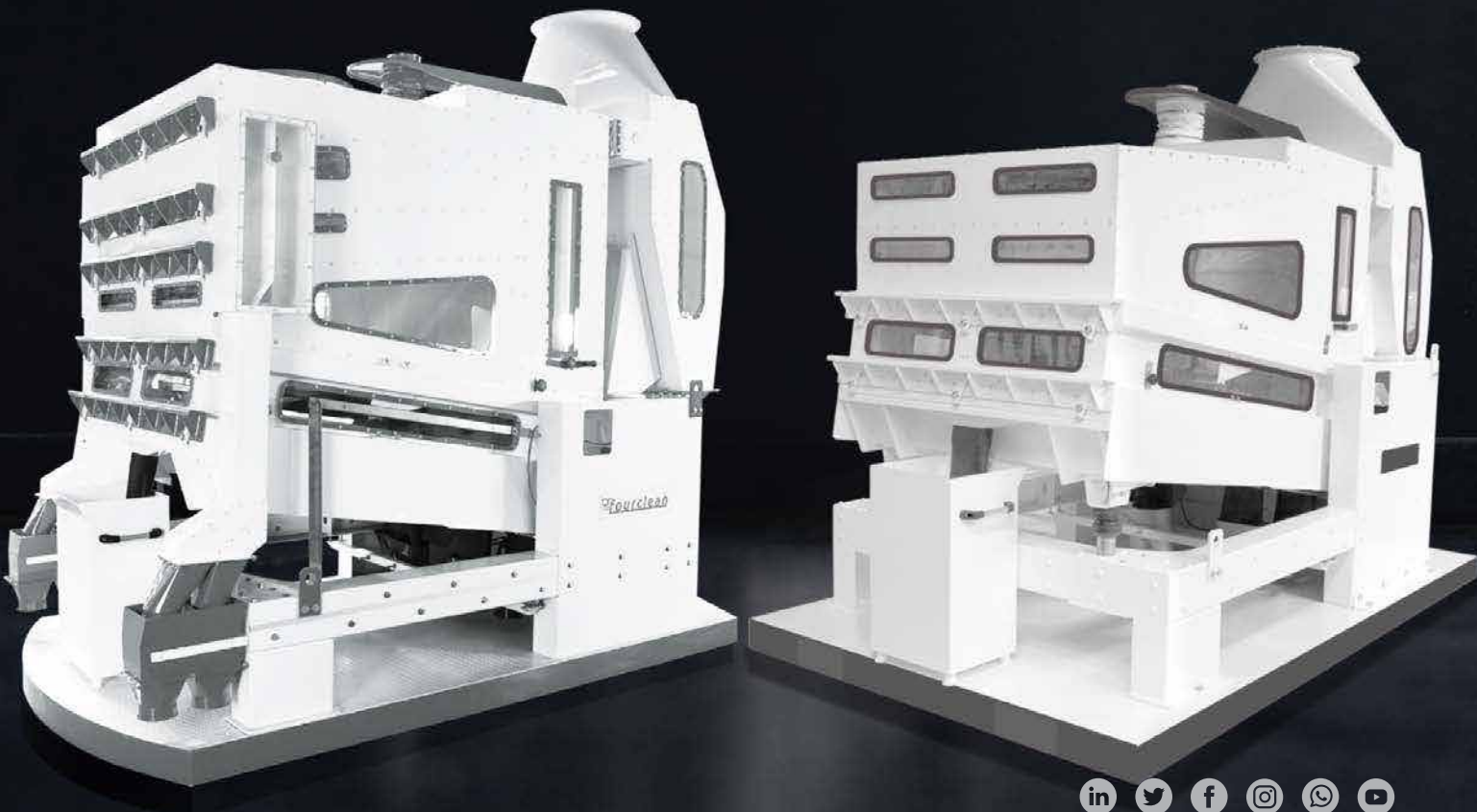

## Model F1

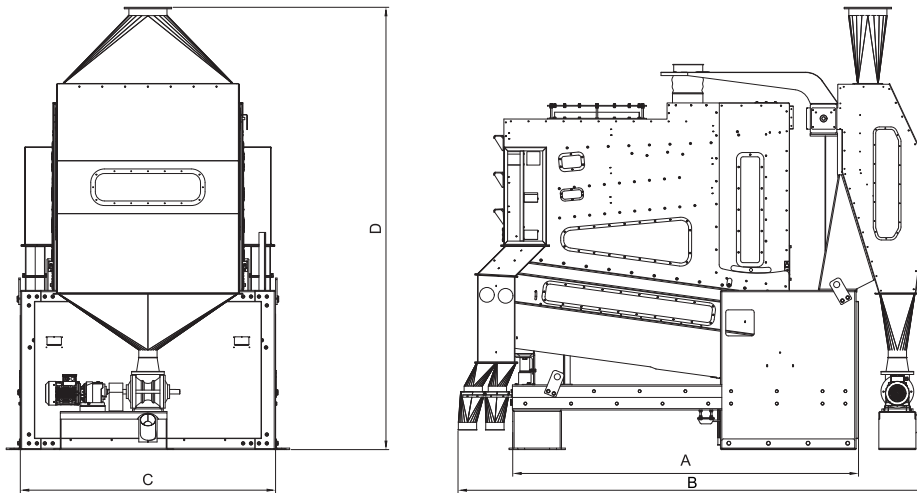

Type	Technical Features		Dimensions (mm)				Weight (kg)
	Capacity (t/h)	Power(kw)	A	B	C	D	
	*Cleaning						
GKC 130 x 130	12 - 14	2 x 0.72 (Vibro)	2255	1675	2900	3075	2250
GKC 65 x 130	5 - 6	1 x 0.55			1015		1435

## Model F2

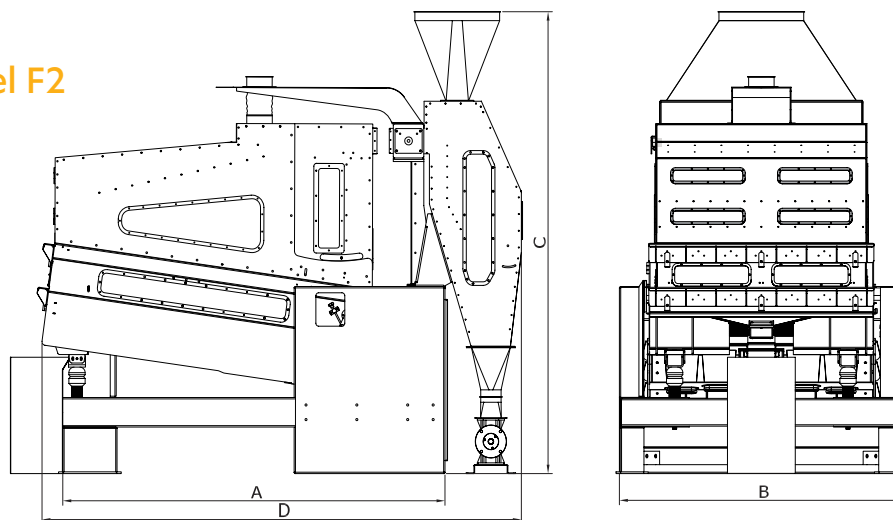

Type	Technical Features		Dimensions(mm)				Weight (kg)
	Capacity (t/h)	Power(kw)	A	B	C	D	
	*Cleaning						
GKC 130 x 130	15-20	2 x 0.56 (Vibro)	2270	1675	2580	2830	1750
		1 x 0.55					

\* Capacity has given as per 2 to 3 % impurity and maximum %13 humidity.

\* Capacity for corn (maize) 90%

\* Capacity for barley 80%