

Air Channel GHV



Excellent Milling Properties...

WORKING PRINCIPLES

It is used to separate unwanted low density materials in grain by aspiration.



Product Data Sheet

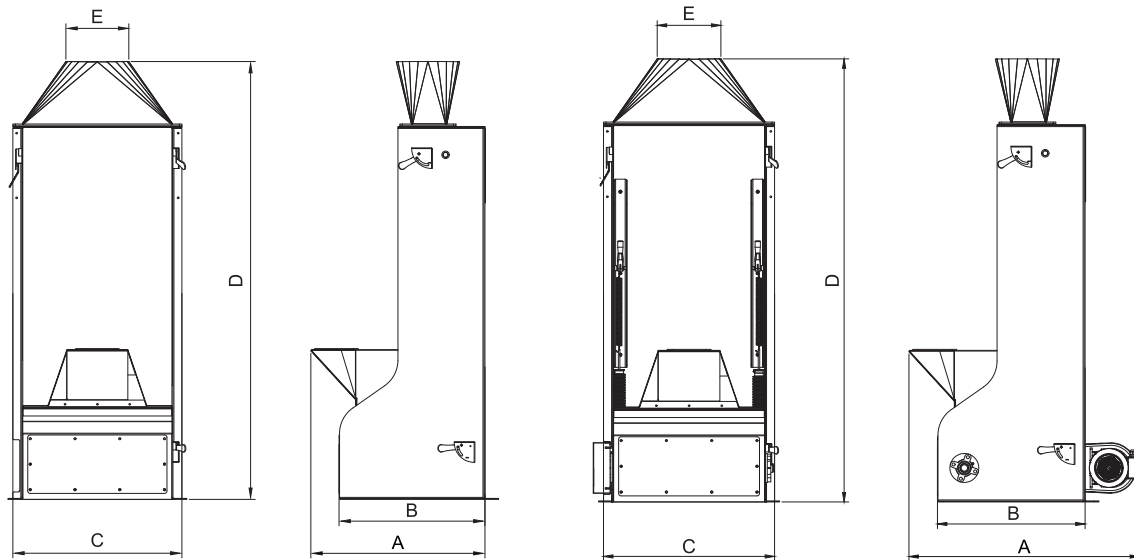

Type	Technical Features				Dimensions(mm)						Weight (kg)
	Capacity (t/h)	Volume (m ³)	Power (kw)	Air Required (m ³ /min)	A	B	C	D	ØE	F	
GVH 060	4	0.3	--	40	600	600	610	1760	250	200	105
			0.085* (vibro)		810						140
GVH 080	6-8	0.43	--	50	600	600	810	1760	300	200	95
			0.085* (vibro)		810						125
GHV 100	10-14	0.65	--	80	600	600	1010	1760	350	200	120
			0.085* (vibro)		810						160
GHV 150	20	0.9	--	120	600	600	1510	1760	450	200	165
			0.17* (vibro)		810						295