

# Air-Recycling Tarar GKRT



*Excellent Milling Properties...*

## WORKING PRINCIPLES

Radial Tarar is used for separate low density things such as dust, glume, weak grains from the high density grains by air recycling aspiration system.



## Product Data Sheet

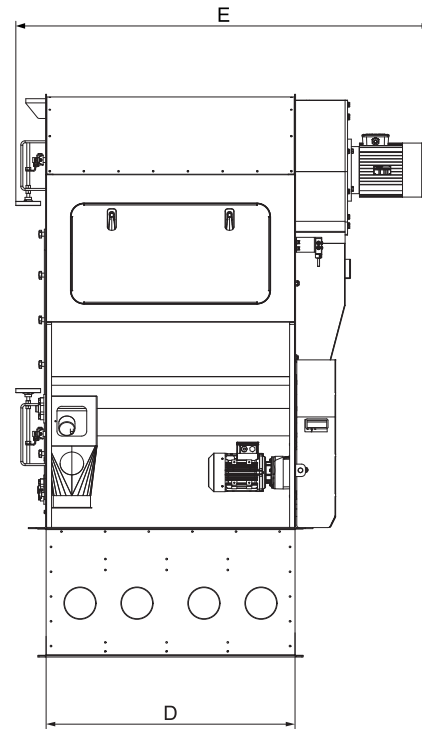
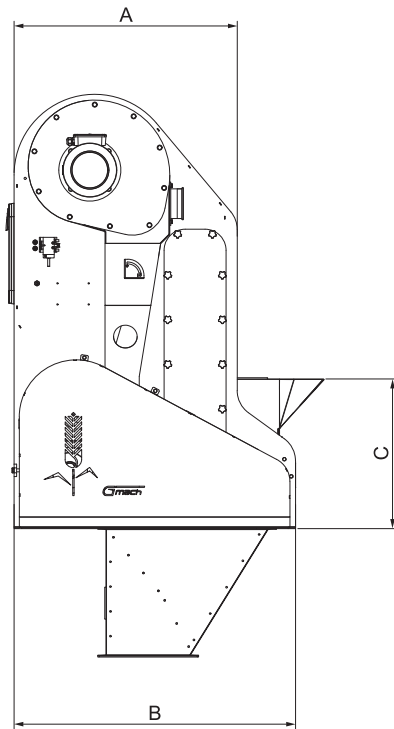

Type	Technical Features			Dimensions(mm)						Weight (kg)
	Capacity (t/h)	Volume (m <sup>3</sup> )	Asp. Power (kw)	A	B	C	D	E	F	
GKRT 60	5-6	0.55	4	900	1135	655	608	1155	120	460
GKRT 80	6-8	0.55	4	900	1135	655	808	1355	120	550
GKRT 100	12-14	0.55	4	900	1135	655	1008	1555	150	580
GKRT 150	18-20	0.55	2 x 4	900	1135	655	1508	2600	150	970