

# Tube Screw Conveyor GTH



*Excellent Milling Properties...*

## WORKING PRINCIPLES

Tubular Screw Conveyor is used to transport all product which has low stickiness rate.



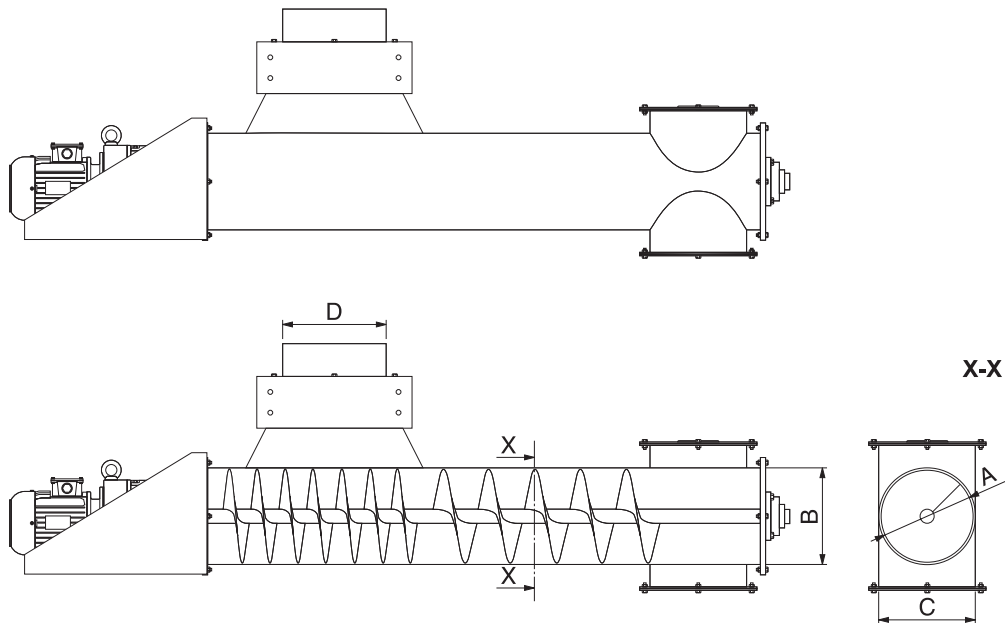

Type	Technical Features					Dimensions (mm)			
	Max Length (m)	Capacity (t/h)			Power (Kw)	A	B	C	D
		Wheat	Flour	Bran					
GTH 150	3	2-6	1.5 - 4.4	0.6-2	0.75	150	165	165	200
GTH 165	3	3-10	2.3-7.5	1.4-4.7	1.1	165	180	180	200
GTH 180	3	4-12	2.6-9	1.6-5.7	1.5	180	200	200	300
GTH 200	3	8-20	4.5-14	2.8-9	1.5	200	220	220	300
GTH 220	3	10-25	5.5-18	3.5-11	2.2	220	240	240	300
GTH 250	3	14-40	8-27	5-17	3	250	270	270	300
GTH 270	3	25-50	10-34	6-21	3	270	290	290	300
GTH 300	3	30-70	14-47	9-30	4	300	320	320	300
GTH 350	3	40 - 100	22-75	14-47	4	350	370	370	300
GTH 380	3	70 - 130	28-96	18-61	5.5	380	400	400	300