

Blending Machine

GP



Excellent Milling Properties...

WORKING PRINCIPLES

Blending Machine is used to mix raw material which has different quality and different features, thanks to different size of chambers inside machine.



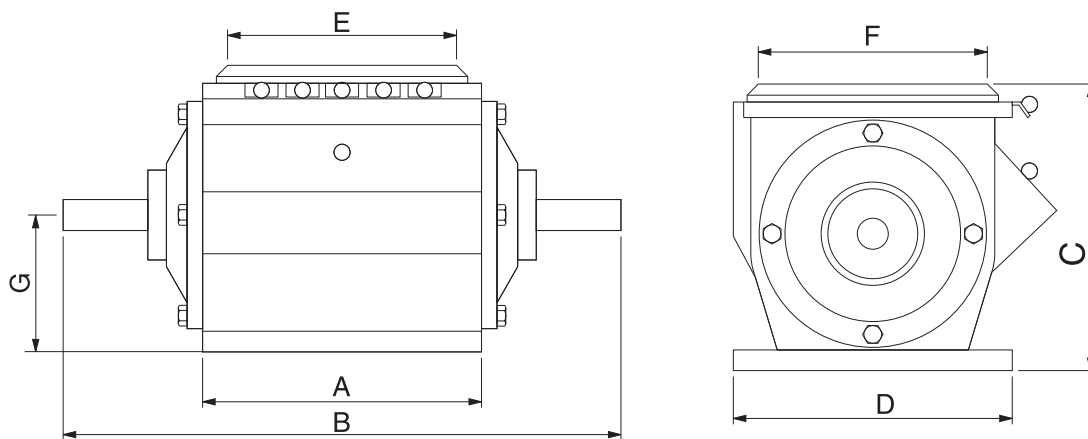

Type	Volume (m ³)	Dimensions (mm)							Weight (kg)
		A	B	C	D	E	F	G	
GP/S	0.26	275	500	355	270	240	170	125	77
GP/L	0.38	355	580	363	300	305	225	160	89
GP/XL	0.70	450	700	425	370	380	280	185	170