

# Pulses Packaging Machine With Four Weigh Hoppers & Single Station 10/25/50 Kg.



*Excellent Milling Properties...*

## **CAPACITY INFORMATION:**

While it varies according to the product to be bagged and the tolerance required, the values relating to the packaging speed below shall provide some information about the capacity of the system.

- 12 ton/hour in 10 kg bagging
- 25 ton/hour in 25 kg bagging
- 45 ton/hour in 50 kg bagging

The tolerance per package varies between  $\pm 0.15$  kg in the 50-kg packaging. In addition to this, it is undertaken to be operated with 45 ton/hour capacity in the products such as flour or in similar characteristics with the average error share per package.

## **PACKAGING SET VALUES**

The package filling weights could be preferred between 10 - 25 - 50 kg by the operator.



# Pulses Packaging Machine With Four Weigh Hoppers & Single Station 10/25/50 Kg.

## Product Data Sheet

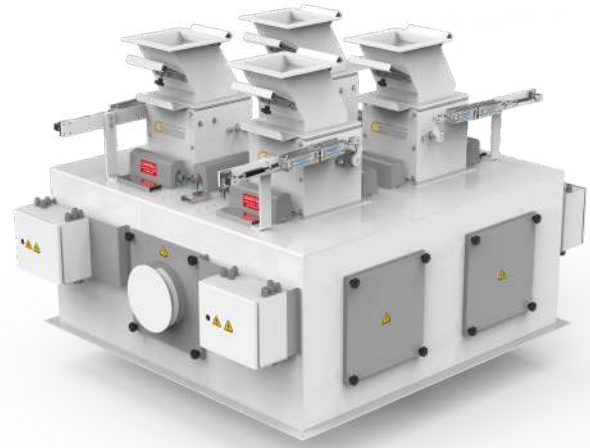

# Pulses Packaging Machine With Four Weigh Hoppers & Single Station 10/25/50 Kg.

## Product Data Sheet

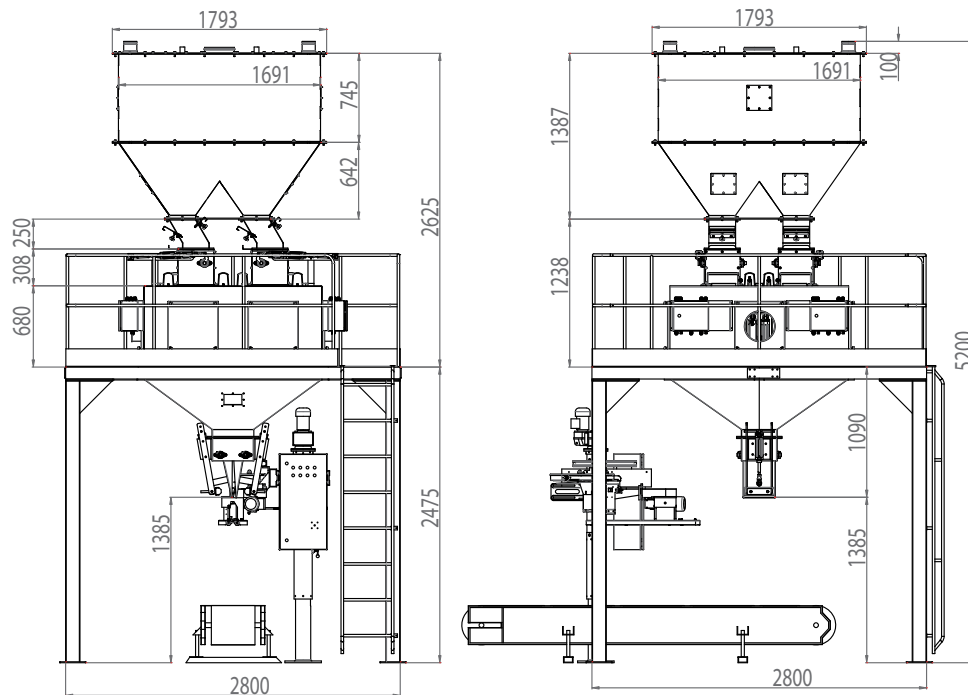

### TECHNICAL FEATURES

Type of Product to Be Packed	Wheat, Chickpeas, Lentils, Beans
Density (Flour)	Variable
Maximum Weighing Weight	Variable
Weighing Range -Options	10 - 25 - 50 Kg
Weighing Accuracy	±% 0,3
Top Bunker Capacity	3.025 Liter
Platter Capacity	4 x 100 Liter
Output Capacity 10 Kg	12,00 Ton/Hour (For Wheat)
Output Capacity 25 Kg	25,00 Ton/Hour (For Wheat)
Output Capacity 50 Kg	45,00 Ton/Hour (For Wheat)
Weighing Units 10 Kg	1.200 Pack./Hour
Weighing Units 25 Kg	1.000 Pack./Hour
Weighing Units 50 Kg	900 Pack./Hour
System Pressure	6 - 8 Bar
Air Supply (m <sup>3</sup> /Min)	40 m <sup>3</sup> /Min
Power Supply (VAC) (+5% - 10%)	400 VAC / 50-60 Hz.
Electricity consumption	2,9 kW/Hour
Weight	3190 Kg