

Flour Bagging Machine System With Double Weigh Hopper & Single Station 25/50 Kg.



Excellent Milling Properties...

CAPACITY INFORMATION:

While it varies according to the product to be bagged and the tolerance required, the values relating to the packaging speed below shall provide some information about the capacity of the system.

- 13,75 ton/hour in 25 kg bagging
- 25 ton/hour in 50 kg bagging

The tolerance per package varies between ± 0.15 kg in the 50-kg packaging. In addition to this, it is undertaken to be operated with 25 ton/hour capacity in the products such as flour or in similar characteristics with the average error share per package.

PACKAGING SET VALUES

The package filling weights could be preferred between 25 - 50 kg by the operator.



Flour Bagging Machine System With Double Weigh Hopper & Single Station 25/50 Kg.

Product Data Sheet

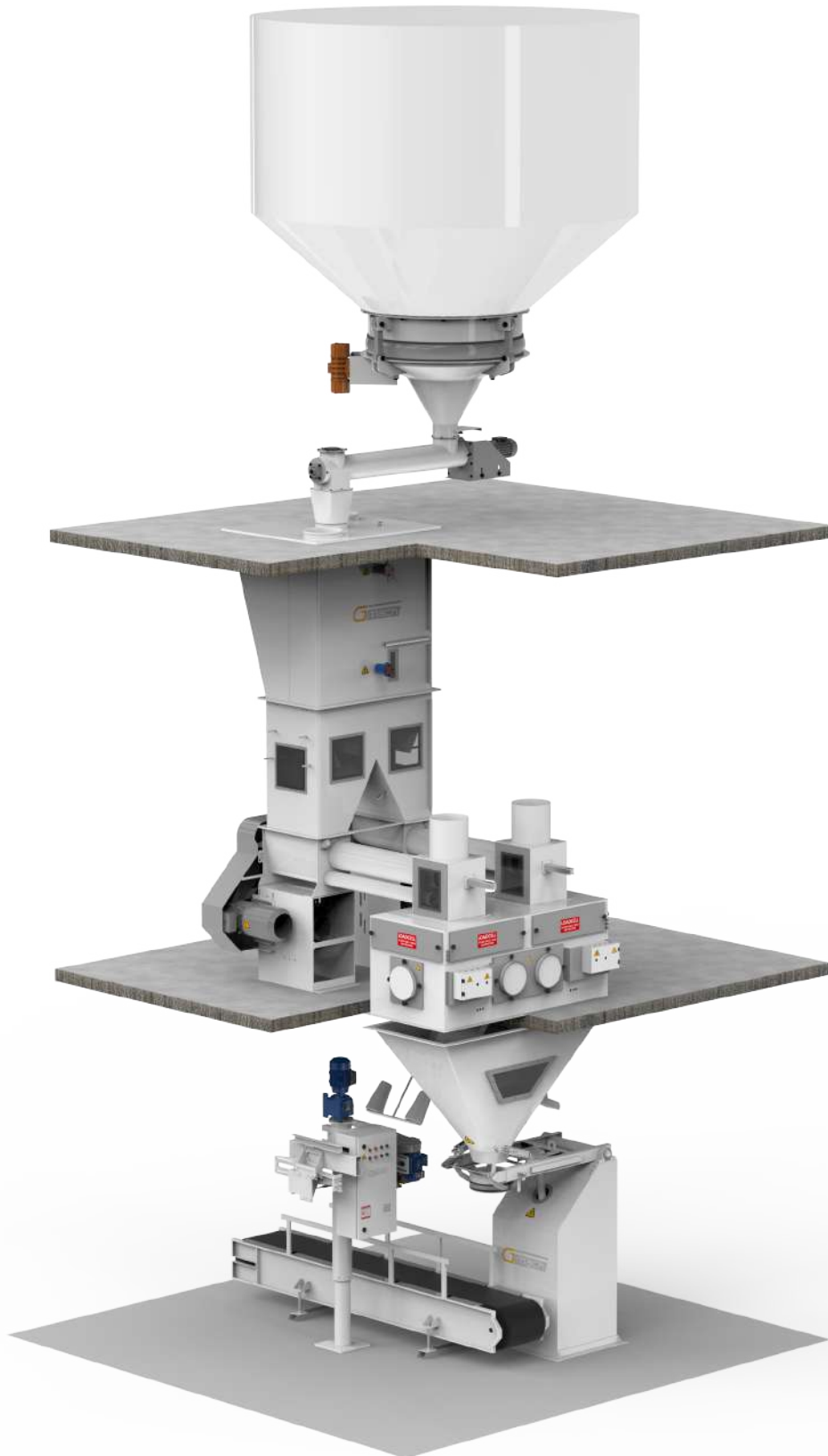

Flour Bagging Machine System With Double Weigh Hopper & Single Station 25/50 Kg.

Product Data Sheet

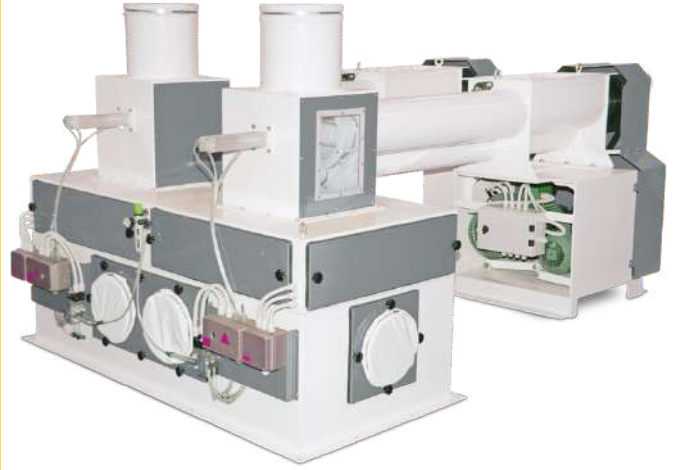

Flour Bagging Machine System With Double Weigh Hopper & Single Station 25/50 Kg.

Product Data Sheet

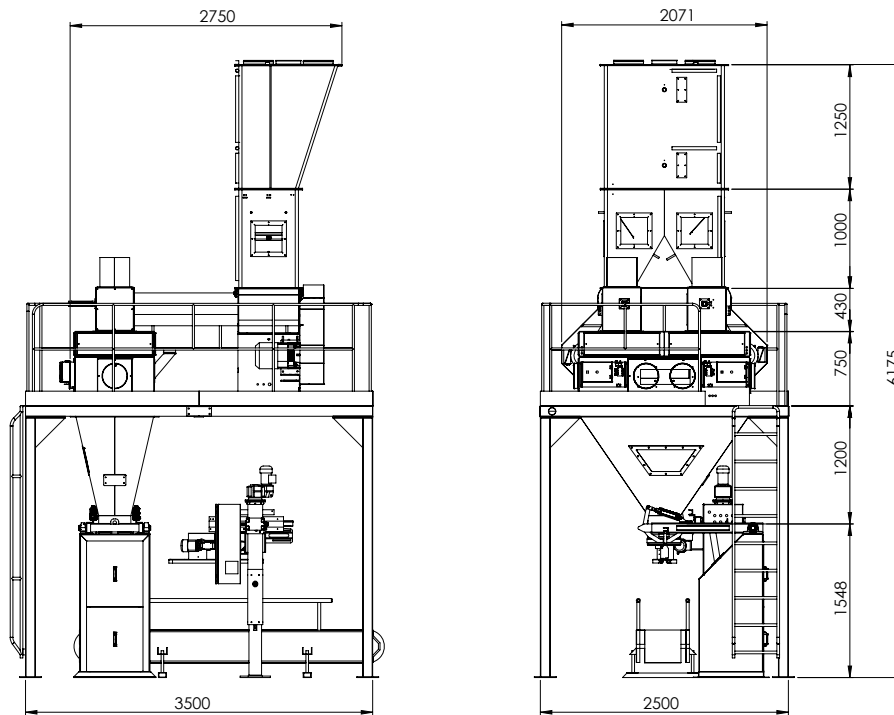

TECHNICAL FEATURES	
Type of Product to Be Packed	Flour
Density (Flour)	0,55 kg/m ³
Maximum Weighing Weight	2x55 Kg
Weighing Range -Options	25 - 50 Kg
Weighing Accuracy	±% 0,3
Top Bunker Capacity	1,645 Liter
Platter Capacity	2x110 Liter
Output Capacity 25 Kg	13,75 Ton/Hour
Output Capacity 50 Kg	25,00 Ton/Hour
Weighing Units 25 Kg	550 Pack./Hour
Weighing Units 50 Kg	500 Pack./Hour
System Pressure	6 - 8 Bar
Air Supply (m ³ /Min)	20 m ³ /Min
Power Supply (VAC) (+5% - 10%)	400 VAC / 50-60 Hz.
Electricity consumption	13,3 kW/Hour
Weight	3760 Kg