

Automatic Mixing (Measurer) System / Flow Balancer - Double Loadcell (10/15 Ton/Hour)



Excellent Milling Properties...

GFBD

GENERAL FEATURES:

The system is designed to increase the quality of the products, efficiency of production, and to increase control (wheat, barley, rye, gruel, rice, lentil, corn and etc. Granulated products), and to mix the products in the desired ratios as prepared mixtures prior to production. Desired mixtures can be prepared according to values entered from the computer or operator terminal by placing a flow control weighing machine under the wheat silos.

The mixture can be prepared by entering total Kg/hour,% ratio numbers or kg/hour for each kind of material.

This improves the efficiency and economy of the grinding machines.

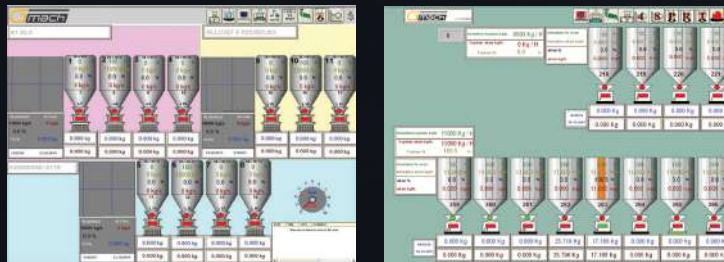

Automatic Mixing (Measurer) System / Flow Balancer - Double Loadcell (10/15 Ton/Hour)

Product Data Sheet

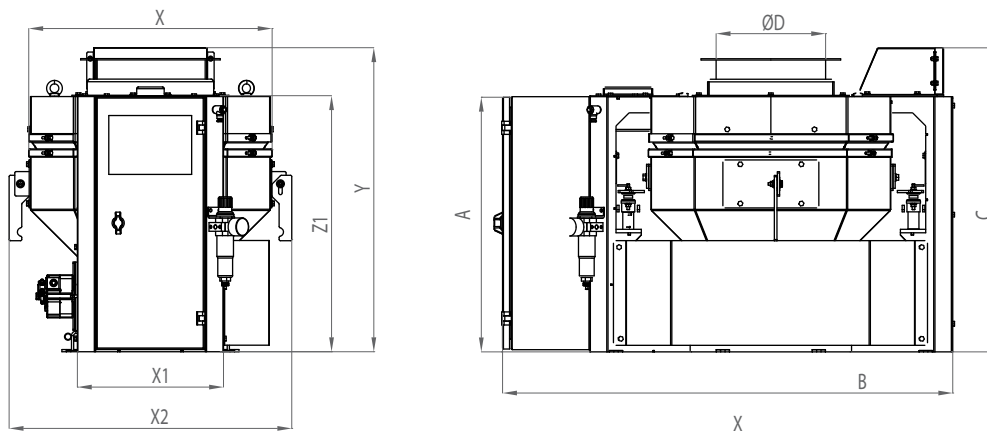

TECHNICAL FEATURES							
Product Code	A	B	C	D	E	Y	Y1
GFBD-10	587	1032	697	558	335	648	697
GFBD-15	587	1032	697	558	335	648	697
GFBD-10 (Crome)	587	1032	697	558	335	648	697
GFBD-15 (Crome)	587	1032	697	558	335	648	697

Product Code	Capacity (Kg/Hour)	Air Supply (Bar)	Weight (Kg)
GFBD-10	0,25 - 11,00	4 - 6	108
GFBD-15	0,50 - 15,00	4 - 6	108
GFBD-10 (Crome)	0,25 - 11,00	4 - 6	108
GFBD-15 (Crome)	0,50 - 15,00	4 - 6	108