

Intensive Degerminator

GIDG

Gmach

Excellent Milling Properties...

WORKING PRINCIPLES

A high degermination degree will be achieved through the intensive processing between roll rotor and screen sieve as well as corresponding adjustment of the retarding pressure in the outlet of the machine.

FEATURES

- Compact Design
- Low Operation Costs
- Uniform Product Quality
- Low Fat Content For Degermination

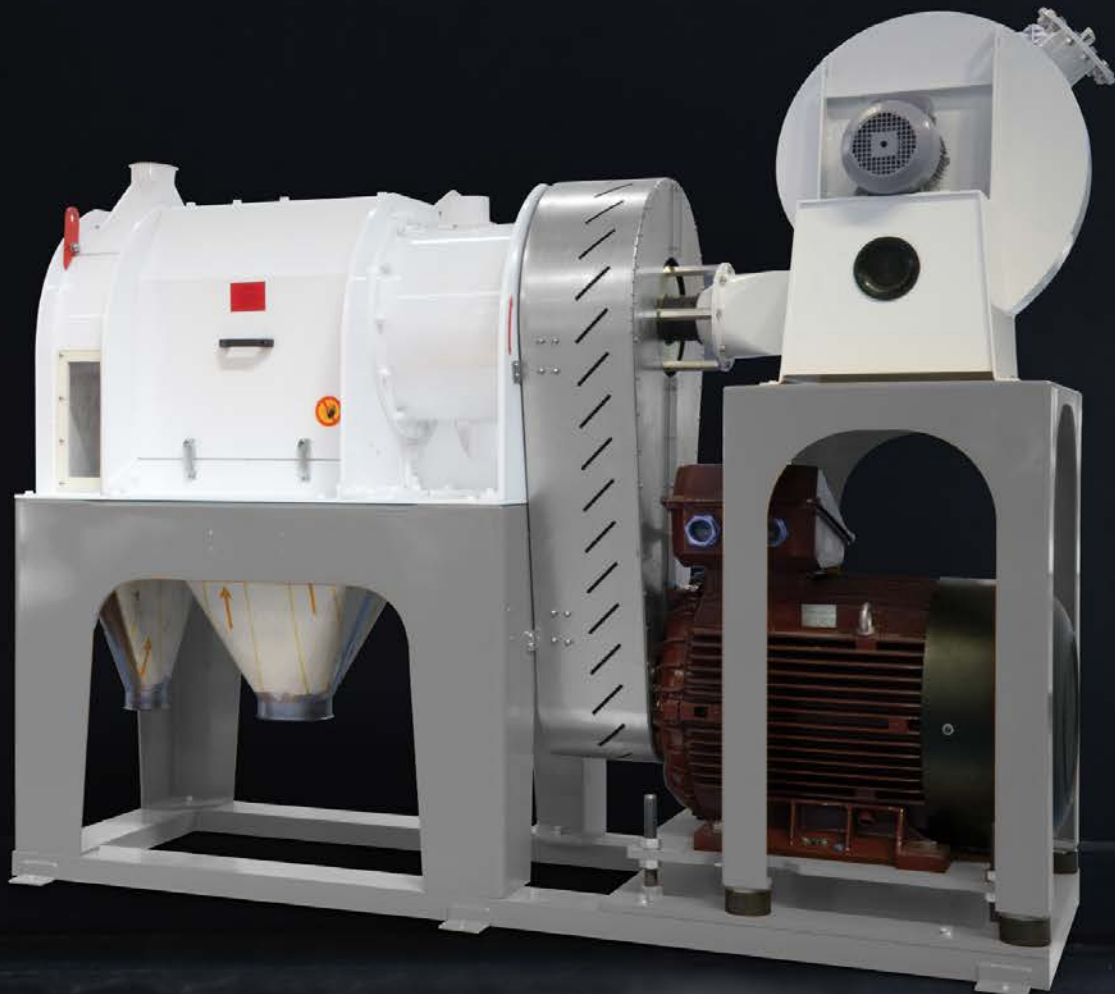

Product Data Sheet

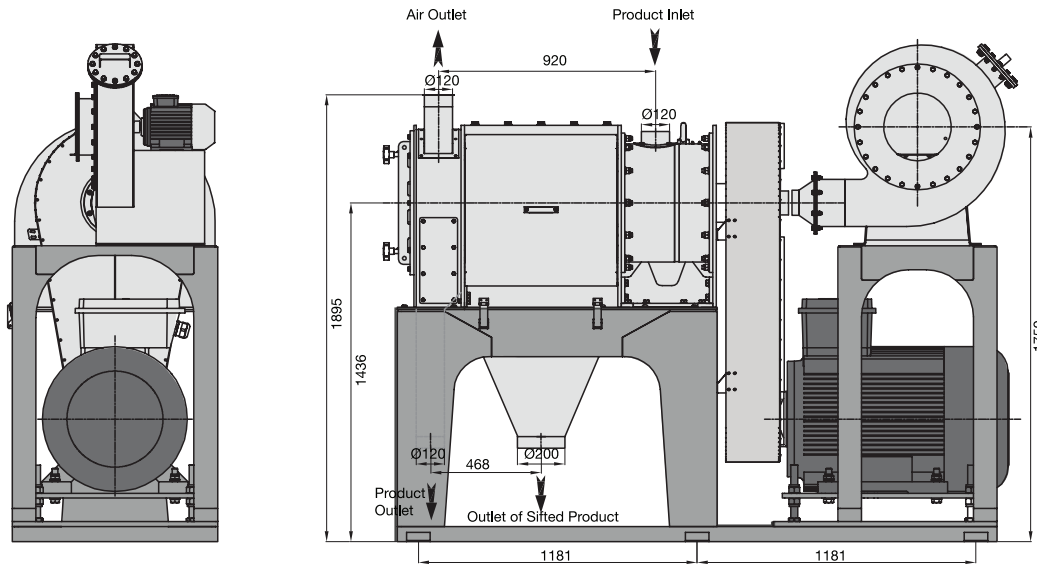

Type	Electrical Motor Rotor		Electrical Motor Fan		Weight(kg)
	kw	rpm	kw	rpm	
GIDG 075	75	750	3	3000	3500